

## Instruction Manual ICOS Air Dryer

Version: 1.2





## Table of contents

1. Safety notes .....	4
2. Intended use .....	5
3. Technical data .....	5
4. Package content .....	6
5. Unpacking .....	7
6. The device .....	8
6.1. Overview .....	8
6.2. Location .....	8
6.3. Connectors and wiring .....	9
6.4. Cooling medium .....	11
6.5. Trap cover .....	13
7. First use .....	14
7.1. First use procedure .....	14
7.2. Short leak test .....	16
8. Operation with touch display .....	18
8.1. Main view .....	18
8.2. Drying cycle settings .....	20
8.3. Cleansing history and error log .....	21
9. Operation with Flask Sampler .....	22
10. Maintenance .....	24
10.1. Oil Cleansing and water removal interval .....	24
10.2. Maintenance of the integrated components .....	24
11. Spare part list / consumables .....	25
12. Contact .....	26

## 1. Safety notes

Read this manual and all safety notes before first use!



Caution glass! The device contains fragile components made of glass and must be handled with care. When working and handling the Dewar containers and glass cylinders, always wear protective goggles and gloves. (safety note by KGW Isotherm)



Electric shock (before opening the device - pull main electricity plug)! Opening the device may only be carried out by qualified personnel! Repairs may only be carried out by the manufacturer or by qualified personnel!



The device may only be used indoor, in a technically perfect condition. Observe the instruction manual!



The sample air must not contain any solid, liquid or combustible substances as these can impair the function of the pumps and valves!



The device may only be used in a technically perfect condition, for their intended use, safely and aware of the dangers and with full observance of the instruction manual!



Slipping-Danger! Immediately wipe up escaped cooling liquid (silicon oil M5).



Note Safety information for cooling liquid (silicon oil M5 low viscosity) in the safety data sheet.

### EC Directives / Standards

For the purposes of the Machinery Directive 2006/42/EC, the device is „partly completed machinery“ and is therefore to be regarded as not ready for use. Partly completed machinery may not be commissioned until such time as it has been determined that the machine in which the partly completed machinery is to be assembled is in conformity with the provisions of the Machinery Directive 2006/42/EC. The essential requirements of Annex I of Directive 2006/42/EC (general principles) are applied and observed.

## 2. Intended use

The ICOS Air Dryer is intended exclusively for scientific purposes. The device should be used with the ICOS Flask Sampler. The ICOS Air Dryer allows drying of the sampled air drawn by the ICOS Flask Sampler to a dew point of less than -35 °C.

## 3. Technical data

### Dimensions and weight

length	48.5 cm
width	84.0 cm
height	53.8 cm
weight	< 90 kg

### Performance data

power supply	230 V AC / 50 Hz
current consumption	≤ 6,3 A
protection class (EN 61140)	IP 20
max. system pressure	1.6 bar(a)
max. inlet pressure	1.6 bar(a) (shall not be exceeded)

### Environmental conditions

ambient temperature	5 °C to 30°C
relative humidity	up to 80 %

### Connections

AIR IN, AIR OUT, WATER OUT	1/4" tube fitting
CAN (9-pin sub-d male)	Connected to ICOS Flask Sampler

## 4. Package content

- ICOS Air Dryer
- Power cable (2 meter)
- D-Sub 9pin male-male cable (3 meter)
- USB-A/USB-B cable (3 meter)
- 1/4" flexible stainless steel tube (1 meter)
- 1/4" flexible polyurethane tube (1 meter; already connected)
- water collecting canister (5 liter)
- silicone oil M 5 low viscous (5 liter)
- Oil pump (OH-703 2,7 liter)
- measuring cup (2 liter)
- Funnel
- Trap cover set (4 pieces)

## 5. Unpacking

**!** Read this instruction manual before first use and unpacking!

1. Check if the tilt and shock indicators have tripped - Figure 1
2. if existing: screw off the ICOS CAL own Transport Data Logger from the shipping container and send it back to: "ICOS, Kahlaische Straße 4, TCF Eingang C, D-07745 Jena, Germany" - Figure 2
3. Open the shipping container and take out the Air Dryer - Figure 3
4. Make sure that the Air Dryer is not damaged. Check especially all glass parts (Dewar, glass cylinder) and check if all tube connections are tighten
5. Open the upper cover - Figure 4 (4 hexagon socket screws - bit size 5)
6. Remove transportation lock - Figure 5
7. Close the upper cover (4 hexagon socket screws - bit size 5, 3 Nm)



Figure 1: shock and tilt indicator



Figure 2: Bosch Transport Logger front/back view



Figure 3: shipping container



Figure 4: upper cover

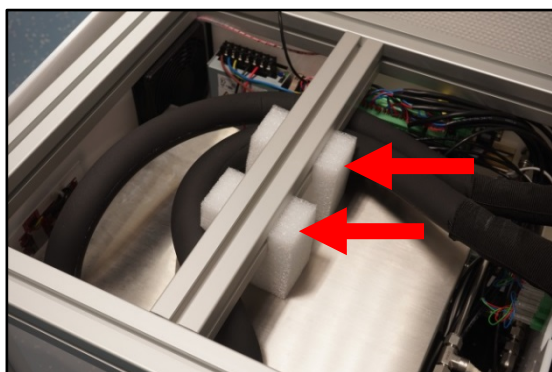

Figure 5: transportation lock

## 6. The device

### 6.1. Overview

The Air Dryer contains two alternately operating freeze-out-water traps for permanent air drying. Each trap consists of a Dewar flask with two glass cylinders (Ø50 mm and Ø70 mm), two temperature sensors, a heating cartridge and a cooling probe which is connected to an immersion cooler. Every cooling trap has an inlet for the cooling medium (silicon oil M5). Remove the blind stop for filling and removing of the coolant.

Inside the device are two immersion coolers, a valve installation with humidity sensors, an over pressure pump and the control electronics. The connectors "AIR IN", "AIR OUT" and the "CAN" interface are on the back side. The connector "WATER OUT" is located behind the Dewar flasks and is connected by a flexible tube to a water collecting canister. The canister must be discharged periodically. In front is located a 5" Touch display to control and observe the Air Dryer.

### 6.2. Location

The device must be operated at a fixed location within a building. Lock all four rollers!

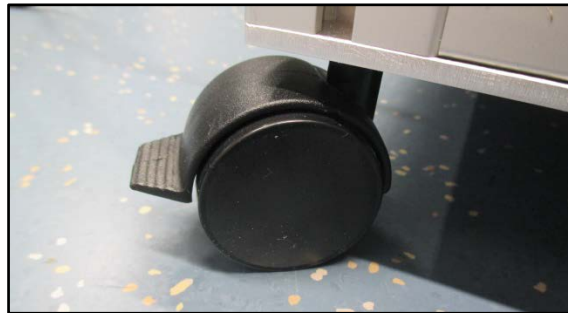

**Figure 6: Locked roller**



## 6.3. Connectors and wiring

### 6.3.1. AIR IN, AIR OUT, CAN

**!** The inlet pressure shall not exceed 1.60 bar(a).

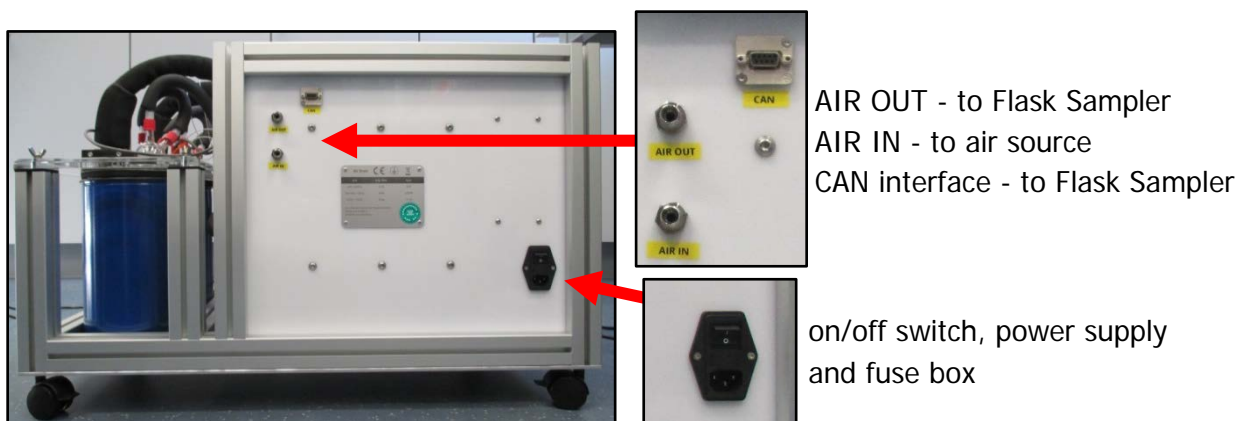

Figure 7: back view

#### AIR OUT

Connect the 1/4" tube fitting with the provided flexible stainless steel tube to the Flask Sampler. Alternatively a suitable 1/4" stainless steel tube can be used.

#### AIR IN

Connect the inlet with a 1/4" tube

#### CAN interface

The CAN interface must be connected to the Flasksampler with a D-Sub 9pin male-male cable.

Sub-D 9-pin female	Description
1	GND
2	GND
3	CAN High
4	NC
5	CAN Low
6	NC
7	NC
8	NC
9	NC

### 6.3.2. WATER OUT

**!** It's necessary to discharge water collecting canister periodically (see 10.1)!

Connect the 1/4" fitting with the provided flexible polyurethane tube to the water collecting canister.

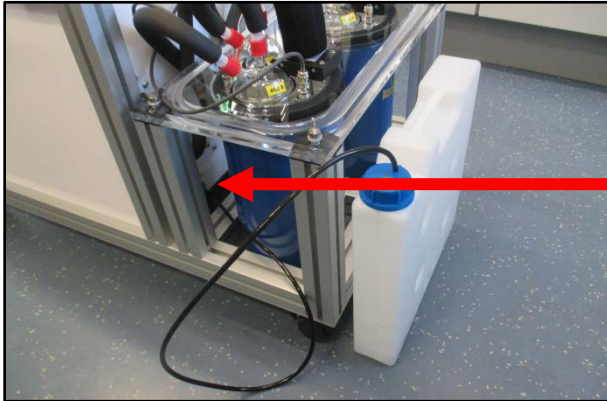

WATER OUT – connected  
to water collecting canister

**Figure 8: WATER OUT connection**

## 6.4. Cooling medium

! Only use "silicone oil M 5 low viscous"! (Item number: 7844 Carl Roth GmbH + Co. KG)

! It's necessary to refill the Dewar container periodically (see 10.1) to avoid water in the cooling medium. Exact 1800 ml must be filled in every Dewar container. (Check that the Dewar container is completely empty before filling)

### 6.4.1. Filling in cooling medium

1. Open filler cap (see Figure 9)
2. Put the funnel in the designated inlet
3. Fill the measuring cup with **1800 ml silicone oil M 5**
4. Fill the oil slowly in the funnel until the measuring cup is empty (see Figure 10)
5. Close the filler cap (see Figure 9)
6. Reset the number of working hours (see 8.3)

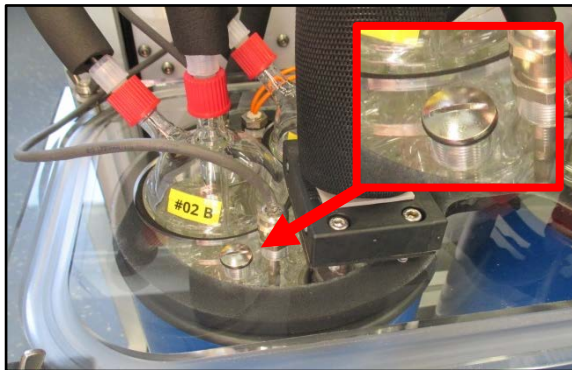

Figure 9: filler cap



Figure 10: filling in cooling medium

! For a faster filling, remove the marked screw (Figure 11) and don't forget to screw in after filling completion.

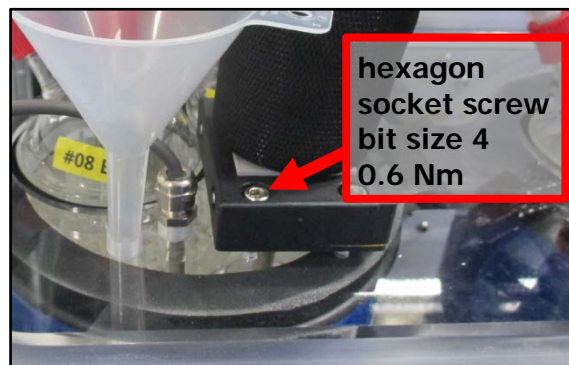

Figure 11: remove screw

### 6.4.2. Evacuate cooling medium

Before removing the oil / water mixture, make sure that the temperature in the trap is at least +15 ° C. Otherwise the water at the bottom of the trap is still be frozen.

1. Open filler cap (see Figure 9)
2. Insert pump tube into the inlet until it hitting ground and pump off the cooling medium (Figure 12)
3. Remove water (see 6.4.3) and fill in cooling medium again (see 6.4.1)
4. Close filler cap (see Figure 9)

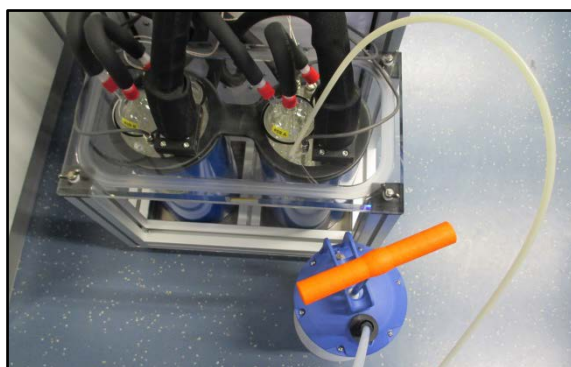

Figure 12: evacuate cooling medium

### 6.4.3. Remove water from cooling medium

To re-use the evacuated cooling medium, it is sufficient to remove the included water:

1. Evacuate cooling medium (6.4.2) an dump from pump to measuring cup
2. Use empty pump to remove water and all bubbles in the cooling medium (water is located at the ground see Figure 13)
3. Empty the pump (Dispose the liquid professional!)
4. Reuse the water free cooling medium and add new silicone oil M5 until the 1800 ml mark of the measuring cup. Fill in as described in 6.4.1
5. put the trap cover back in place (see 6.5)

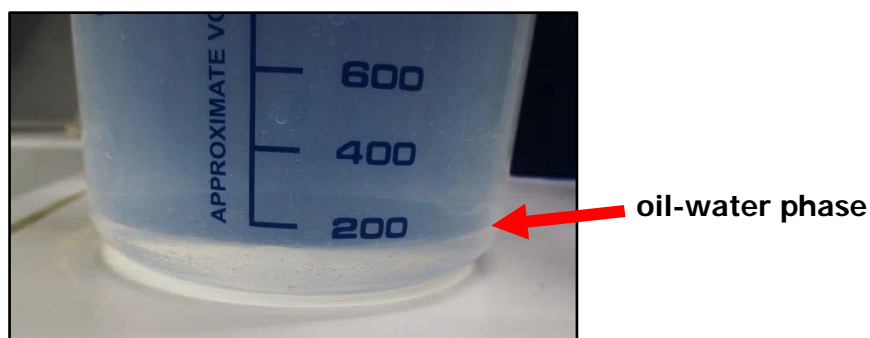

Figure 13: oil-water phase

## 6.5. Trap cover

To reduce the oil cleansing interval a trap cover (pictures below) is preventing condensate seeping into the Dewar container.

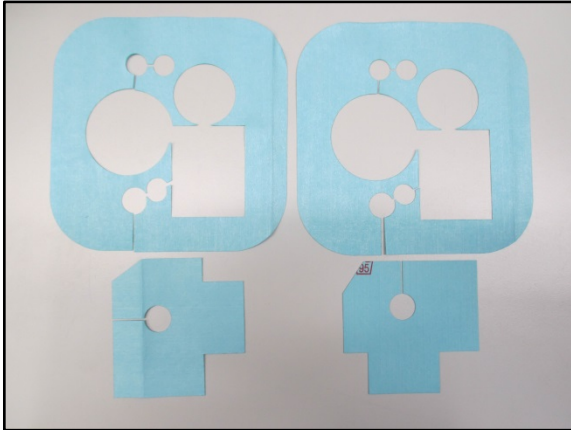

Figure 14: set of trap cover

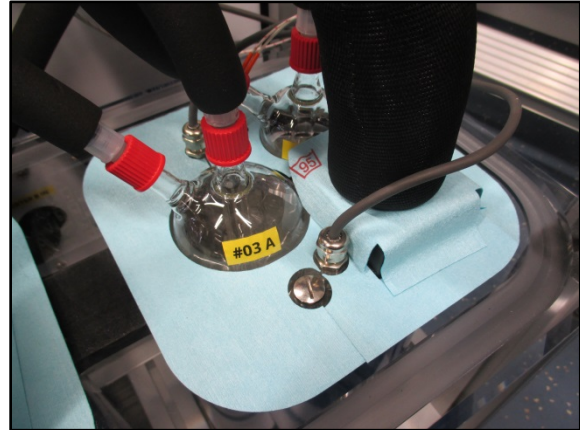

Figure 15: position of the trap cover

## 7. First use

### 7.1. First use procedure

**!** Read this instruction manual before first use and unpacking!

**!** Remove transportation lock before first use (see 5.) and read the next steps!

1. Turn on the on/off switch at the back
2. Make a short leak test (see 7.2) before fill in cooling medium to ensure that no glass cylinder has been damaged during transport!
3. Fill in cooling medium in freeze-out-trap A and B (see 6.4)
4. Put on the trap cover (see 6.5)
5. Connect the ¼" flexible polyurethane tube with the water collecting canister (see 6.3.2)
6. Connect the ¼" meter flexible stainless steel tube between Air Dryer "AIR OUT" and Flask Sampler "AIR IN" (see 6.3.1)
7. Connect the Air Dryer "AIR IN" to the air source or leave free for a drying test with ambient air
8. Connect the Air Dryer and Flask Sampler with a D-Sub 9-pin mal-male cable (see 6.3.1)
9. Start a drying cycle by using the touch display (chapter 8) or use the Flask Sampler software (chapter 9)

#### Start Air Dryer by using touch display:

1. Press "control" on main view

**Control**

2. Press "start dryer" (activate "nonstop drying" – see 8.2)

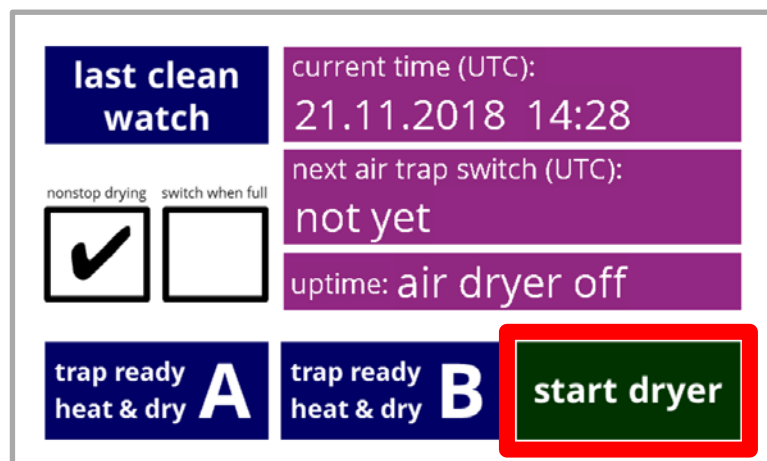

Figure 16: touch display - start dryer



Start Air Dryer by using Flask Sampler:

1. open "drying unit" tab
2. press "start dryer" button (activate "nonstop drying" - see 8.2)

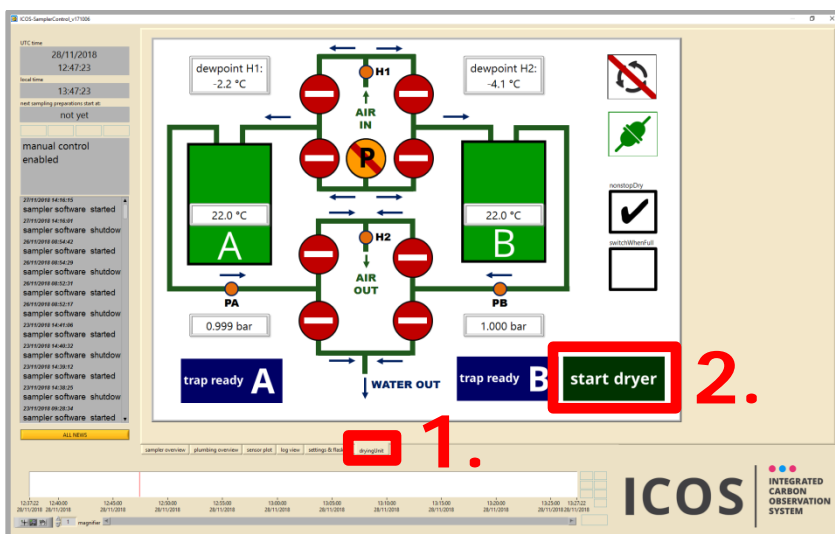

Figure 17: flask sampler software - start dryer

Check the drying process with help of the sensor plot:

1. open "sensor plot" tab

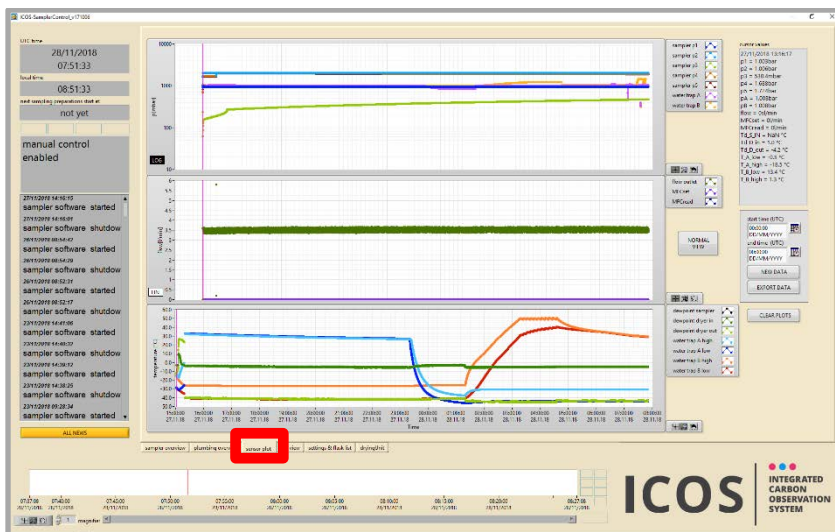

Figure 18: flask sampler software - start dryer

## 7.2. Short leak test



Make this short leak test before first use and after every transport to be sure that no glass cylinder has been damaged.

<ol style="list-style-type: none"> <li>1. Turn on the Air Dryer and see the main view (after touching the display one time or wait until the ICOS logo is gone)</li> <li>2. Press the right corner of the touch display for more than 5 seconds to enter panel for direct control. NEVER access this panel in normal operation!!!</li> </ol>	
<ol style="list-style-type: none"> <li>3. Open valve A2 and turn on the internal pump by touching each symbol one time</li> <li>4. If the pressure (sensor PA) rises above 1.6 bar, everything is ok. Otherwise a glass cylinder is damaged or a connection is not tight</li> <li>5. Close valve A2 and turn off the pump. Open valve A4 for a short moment to deflate the pressure</li> </ol>	
<ol style="list-style-type: none"> <li>6. Repeat Procedure for trap B. Open Valve B2 and turn on the pump. The test is passed when the pressure (sensor PB) rises above 1.6 bar.</li> <li>7. Close valve B2 and turn off the pump. Open valve B4 for a short moment to deflate the pressure</li> </ol>	



8. Be sure that all components are off:
9. Leave the test view by pressing the "main" button

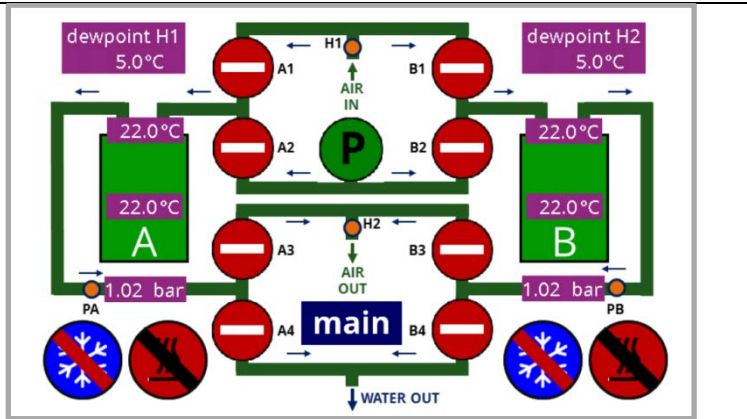

## 8. Operation with touch display

### 8.1. Main view

After turning-on (on/off switch - see 6.3.1) you will see the following screen (touching the display once will close the intro):

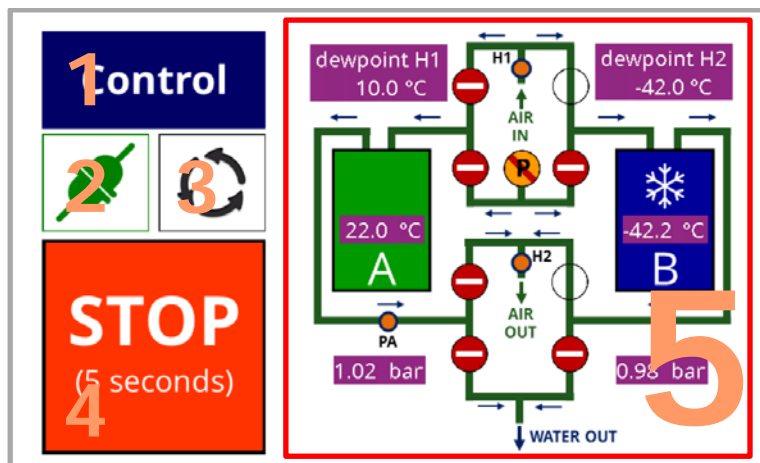

Figure 19: Main view

#### 1 – Control button

Press this button to navigate through screen views

#### 2 – Connection symbol

Indicates if Air Dryer is connected to Flask Sampler:



no connection (check cable between Air Dryer and Flask Sampler)



connected to the Flask Sampler

#### 3 – Cycle on/off symbol

Shows if a drying cycle is active:



drying cycle is running



drying cycle is off



drying cycle was interrupted by an error (check error messages)



drying cycle is controlled by remote (Flask Sampler)

#### 4 – STOP button

Press this button 5 seconds to switch off all components in an emergency (chillers, heaters, valves, pump)

## 5 – Flow scheme with sensor data and switching states

The flow scheme shows the current state of all integrated valves, chillers, sensors and the pump with the following symbols:

### magnet valves and pump states:



valve closed



Valve open



pump off



pump on

### freeze-out-trap states:



chiller on, blue color indicates cold temperatures



heater on, red color indicates hot temperatures



chiller off, heater off, green color indicates medium temperatures



sensor error (check temperature sensors)

### sensor data:

<b>H1</b>	dewpoint H1 10.0 °C	humidity - AIR IN
<b>H2</b>	dewpoint H2 -42.0 °C	humidity - AIR OUT
<b>PA</b>	1.02 bar	pressure - trap A
<b>PB</b>	0.98 bar	pressure - trap B
<b>TA</b>	22.0 °C	temperature - trap A
<b>TB</b>	-42.2 °C	temperature - trap B

## 8.2. Drying cycle settings

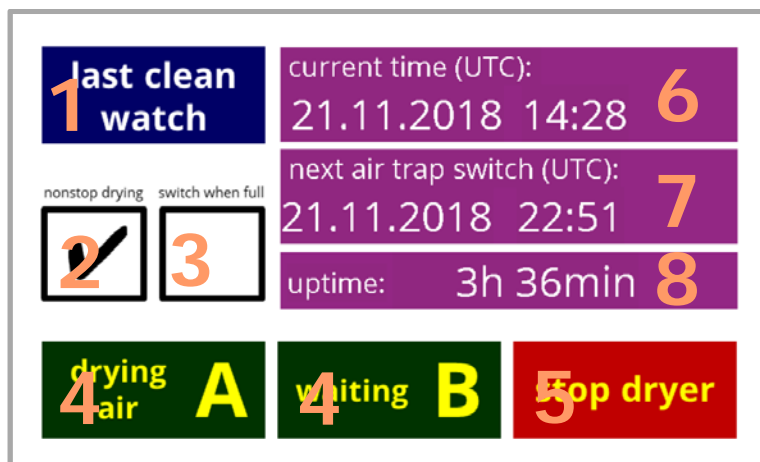

Figure 20: cycle settings

### 1 – last clean watch button

Press this button to navigate through screen views

### 2 – nonstop drying button

Press this button to activate a nonstop drying cycle, otherwise the dryer stops after one iteration

### 3 – switch when full button

not active: automatic switching between trap A and B with a preset time interval

active: switching between trap A and B when trap is blogged by ice, no preset switching interval is active

### 4 – state trap A/B

Indicates the state of trap A/B and displays errors.



If the drying cycle has been stopped without regeneration, the “trap wet - heat & dry” button is active.

### 5 – start/stop dryer button

Starts or stops the drying process (not active if Air Dryer is remote controlled by Flask Sampler)

### 6 – current time

Indicates the system time (synchronized by connection to Flask Sampler)

### 7 – next trap switch time

Shows the next switching time between trap A/B (if “switch when full” is active, no time is displayed)

### 8 – uptime

Shows the uninterrupted drying time

### 8.3. Cleansing history and error log

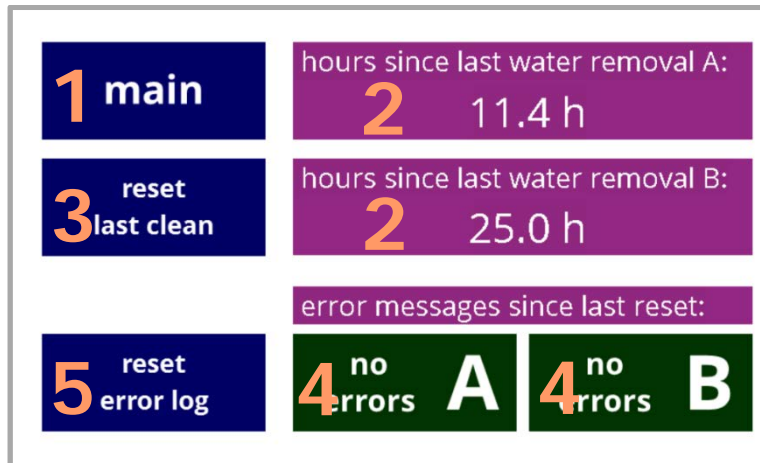

Figure 21: cleansing history and error log

#### 1 – main button

Press this button to navigate through screen views

#### 2 – hours since last water removal A/B

Number of working hours since the last reset. Water removal means the last change of cooling medium.

#### 3 – reset clean button

Reset the counter of trap A and B (push this button after changing the cooling medium)

#### 4 – error messages

Shows occurred errors (e.g. sensor problems, oil cleansing necessary, etc.)

#### 5 – reset error log button

Reset all error messages. Be sure that the error is fixed!

## 9. Operation with Flask Sampler

It's sufficient to control the Air Dryer only by the Flask Sampler software. The tab "drying unit" allows you to control all settings and shows the state of both freeze-out-water traps:

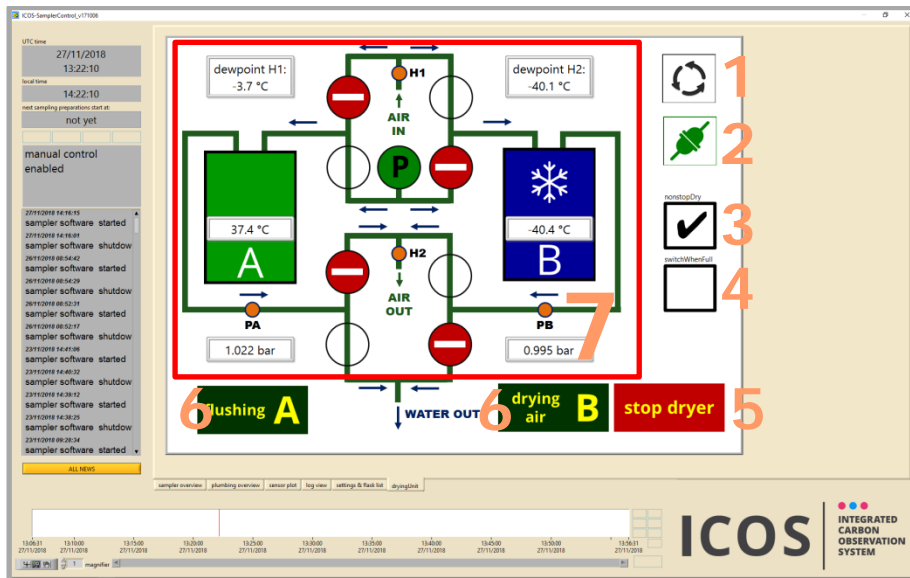

Figure 22: tab "drying unit"

### 1 – Cycle on/off symbol

Shows if a drying cycle is active

### 2 – Connection symbol

Indicates if Air Dryer is connected to Flask Sampler

### 3 – nonstop drying button

Press this button to activate a nonstop drying cycle, otherwise the dryer stops after one cycle

### 4 – switch when full button

not active: automatic switching between trap A and B with a preset time interval

active: switching between trap A and B whenever a trap is blocked by ice, no preset switching interval is active

### 5 – start/stop dryer button

Starts or stops the drying process.

### 6 – state trap A/B

Indicates the state of trap A/B and displays errors.

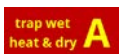

If the drying cycle has been stopped without regeneration, the "trap wet - heat & dry" button is active.

### 7 – Flow scheme with sensor data and switching states

In this flow scheme are shown all integrated valves, chillers, sensors and the pump. (The displayed symbols are identical as described in 8.1)

## 10. Maintenance

### 10.1. Oil Cleansing and water removal interval

**!** The following steps must be carried out in a short interval!

Necessary activity		Interval
1.	Oil cleansing trap A and B (see 6.4)	After 500 operating hours or after one months (which case occurs first)
2.	Water removal (water collecting canister) (see 6.3.2)	One time per month

### 10.2. Maintenance of the integrated components



Electric shock (before opening the device - pull main electricity plug)! Opening the device may only be carried out by qualified personnel!



Repairs may only be carried out by the manufacturer or by qualified personnel!

These maintenance steps must be done within the specified period.

Maintenance steps		every 2 years
1.	Check if all screw connections and tube fittings are tighten	X
2.	Check pump (see maintenance specifications of the manufacturer)	X
3.	Battery for real time clock (CR1220 3V)	x

#### Pump KNF 850.1.2 KNDCB<sup>1</sup>

No maintenance specifications of the manufacturer. Replace membrane, valve plate and o-rings when pumping capacity decreases, or sooner.

<sup>1</sup> KNF 850.1.2 KNDCB Operation and Installation Instructions page 14-17 "servicing"



## 11. Spare part list / consumables

spare part name	item number	supplier
silicone oil M5, 5 l	7844.2	Carl Roth GmbH + Co. KG <a href="http://www.carlroth.com">www.carlroth.com</a>

## 12. Contact

Flask and Calibration Laboratory (FCL)  
Integrated Carbon Observation System (ICOS)  
Max-Planck-Institute for Biogeochemistry  
Kahlaische Straße 4 / Eingang A  
D-07745 Jena  
Germany  
[flasksampler@bgc-jena.mpg.de](mailto:flasksampler@bgc-jena.mpg.de)  
<http://www.icos-cal.eu/fcl>